

- Quiet operation
- Zero maintenance
- Design prevents backflow
- Will seal around solids
- Designed to withstand wear
- Tough enough for abrasive slurries



The Series CPO Slip-On Check Valve is designed to be efficient, quiet and tough. It requires no external power sources, thereby reducing operation costs. The valve's simple design means there are no moving mechanical parts to break down or jam, reducing maintenance costs.

CPO Valves easily handle corrosive or abrasive materials such as raw sewage, sludges or slurries. Their flexible design allows solids to pass through unhindered and can even seal around solids trapped in the valve.

Series CPO Slip-On Check Valves are versatile and can be installed either horizontally or vertically. Drilling is available in all flange standards.

#### Typical Applications

Sewer Interceptors - Wet Wells - Mine Tailing Systems - Dredging - Scrubber Systems - Outfall Lines - Wet/Dry Wells

Designed to mount directly on existing piping, the Series CPO Valve is held in place with durable stainless steel clamps.

The CPO Series valve allows material to flow through...

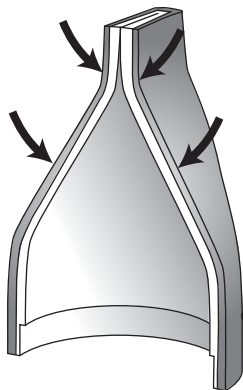
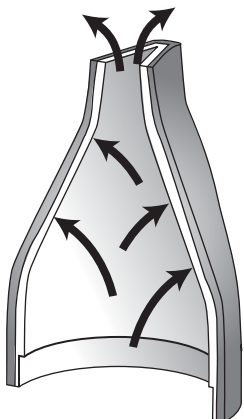

...and then prevents it from returning to its source.

The heart of the Elasto-Valve Series CPO Backflow Preventer is a fabric reinforced rubber "duckbill" sleeve manufactured with top quality materials. This flexible sleeve provides maximum flow with a minimum pressure drop across the valve at all times.

Unlike conventional check valves - which require frequent maintenance to replace worn seats, hinge pins, balls or flappers - there is little or no maintenance with CPO Valves.

Available in a variety of styles and reinforced elastomers, the Elasto-Valve Series CPO Backflow Preventer can be adapted to almost any application.

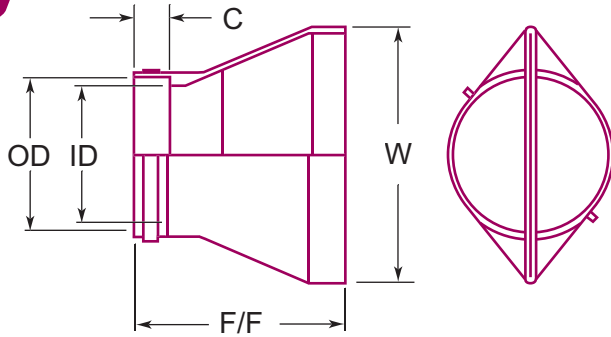

For engineering specifications or when placing your order, please provide the following information:

	Minimum	Maximum
Flow Rate	<input type="text"/>	<input type="text"/>
Flow Velocity	<input type="text"/>	<input type="text"/>
Line Pressure	<input type="text"/>	<input type="text"/>
Back Pressure	<input type="text"/>	<input type="text"/>
Mounting Pipe:	<input type="text"/> I.D.	<input type="text"/> O.D.
Discharge:	<input type="checkbox"/> Atmosphere	<input type="checkbox"/> Water
Type of Clamp:	<input type="checkbox"/> SS316	<input type="checkbox"/> Other

<b>ID<sup>1</sup></b>	1/2	3/4	1	1-1/2	2	2-1/2	3	4	5	6	8	10	12	14
<b>F/F<sup>1</sup></b>	2-1/2	3	3-1/4	4-1/2	5-3/4	7-1/2	9	12	13	15	17	18	24	26-1/2
<b>C<sup>1</sup></b>	1	1	1	1	1-1/2	2	3	3	3	4	4	4	6	6
<b>W<sup>1</sup></b>	1	1-1/2	2-1/8	2-5/8	3-7/8	4-5/8	5-1/2	7-3/8	8-3/4	10-1/2	13-3/4	17	19-5/8	24-3/4
<b>Weight<sup>2</sup></b>	.25	.75	1.5	3.8	4.75	7.6	10.45	14.25	16.15	20	23.75	35.15	56	71.25
<b>ID<sup>1</sup></b>	16	18	20	24	28	30	32	36	42	48	54	60	63	72
<b>F/F<sup>1</sup></b>	28	31	32	41	44	46	52	58	61	70	74	80	88	97
<b>C<sup>1</sup></b>	6	6	8	8	8	10	10	10	12	12	12	12	12	14
<b>W<sup>1</sup></b>	26-1/2	29-3/4	31-1/2	43	46	49	51	55-1/4	66-1/4	74-1/2	78-1/4	85	92	105
<b>Weight<sup>2</sup></b>	118	195	299	380	451	523	572	621	902	947	1016	1207	1245	1356

1 - inches    2 - pounds (includes Clamp)

Dimensions can be revised to suit custom specifications.

### Elastomer Selection Guide

#### Ethylene Propylene Rubber (EPDM)

Most effective for applications involving water, steam or diluted acids.

#### Viton™ (FKM)

Resists solvents, halogenated hydrocarbons, oxygen, weather, ozone, oils and chemicals.

#### Buna N (NBR)

Resistant to kerosene, moderate chemicals, fats, oils, grease and many hydrocarbons.

#### Natural Rubber (NR)

Good abrasion resistance, tensile strength and resiliency. Also suitable when dealing with organic acids, alcohols, ketones and most moderate chemicals.

#### Hypalon™ (CSM)

Resists strong acids and bases, ozone, weathering, heat and oxidizing chemicals.

#### Butyl (CIIR)

Good resistance to animal and vegetable fats, strong and oxidizing chemicals, oils, heat and greases.

#### Neoprene (CR)

Generally resistant to oil and grease, moderate chemicals, fats, many hydrocarbons and ozone. Resistant to barnacle growth.

When placing your order, please indicate sleeve material by appending elastomer abbreviation (CR, NR, etc) to the model name.  
IE: Series CPO-CR

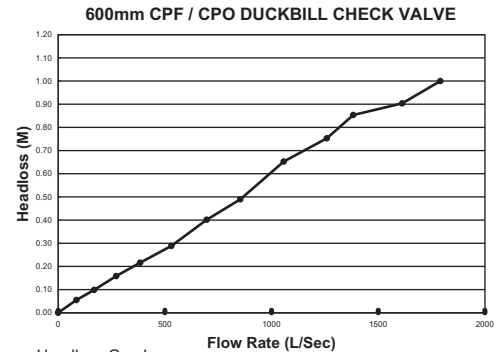
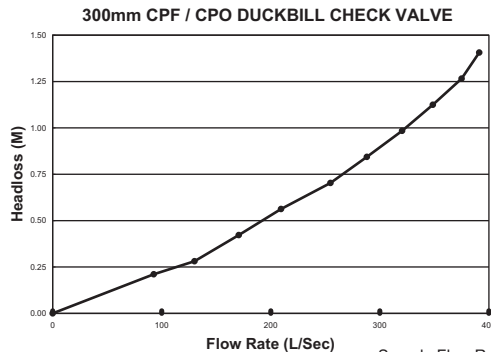

Sample Flow Rate vs. Headloss Graphs.  
Other valve sizes available upon request.  
Based on flow testing at Utah State University.

### WARRANTY

All EVR products are guaranteed for one full year against defects resulting from faulty workmanship or materials. If any such product is found to be defective by reason of faulty workmanship or materials, upon written notice and return of the product, the defective product will be replaced by us free of charge, including the shipping charges for the replacement product. Claims for labour costs and other expenses required to replace such defective product, or to repair damage resulting from the use thereof will not be allowed by us. Our liability is limited to the price paid for the defective product. EVR Products shall not be bound by any warranty other than the above set forth unless such warranty shall be in writing. This literature is published in good faith and is believed to be reliable, however, EVR Products does not represent and/or warrant in any manner the above information and suggestions contained in this brochure. Data presented is the result of laboratory tests and field experience.

Distributed by:

### ELASTO VALVE RUBBER PRODUCTS INC.

1691 Pioneer Road, Sudbury,  
Ontario Canada P3G 1B2  
Tel. (705)523-2026 - Fax. (705)523-2033  
Toll Free 1-800-461-6331 (N.A.)  
Website: [www.evrproducts.com](http://www.evrproducts.com)  
E-mail: [sales@evrproducts.com](mailto:sales@evrproducts.com)

ISO 9001 Certified

