

CPF INSTALLATION, OPERATION, AND MAINTENANCE MANUAL **FLANGED SERIES CHECK VALVE ***



Elasto-Valve's CPF Series is a flanged, bolt-on duckbill Check Valve manufactured with top quality elastomeric materials. Custom engineered and manufactured for each application, its design allows maximum flow with minimal pressure drop across the valve. This flexible valve prevents flow from occurring in the reverse direction. It will eliminate costly backflow from oceans, rivers, or storm water and is the ideal valve for effluent diffuser systems.

The CPF Series duckbill Check Valve is designed to bolt on to an existing pipe flange or headwall (PVC, Concrete, Steel, etc) and is bolted into place with retaining rings. Installation is quick and simple. These valves require no external power source or mechanical components to operate, unlike conventional Check Valves. EVR duckbill Check Valves require little or no maintenance, thereby virtually eliminating operation and maintenance costs.

The Series CPF Check Valve can handle corrosive or abrasive materials such as raw sewage, sludge, or slurries. With a broad selection of elastomers, the Check Valve is suitable for many types of media and a wide range of temperatures.

Advantages of using EVR Duckbill check valves:

- LOW HEADLOSS IN DIRECTION OF FLOW
- MINIMAL MAINTENANCE
- PREVENTS BACKFLOW
- SELF CLEANING
- WITHSTANDS WEAR
- QUIET OPERATION

Normal Check Valve Operation:

EVR Duckbill Check Valves are custom made and are intended for specific applications. They are designed to respond to criteria unique to its purpose, such as line pressure, backflow pressures, and chemical compatibility. Should the conditions be altered or changed significantly, it could affect the normal operation of the valve.

EVR duckbill check valves function based on differential pressure. When the line pressure, (at the valve inlet), exceeds the backpressure, (at the valve outlet), the valve opens and flow is created (**Figure 1 - left picture**). When the backpressure exceeds or overcomes the line pressure, the bill of the valve seals shut, thereby preventing any backflow from occurring, (**Figure 1 - right picture**).

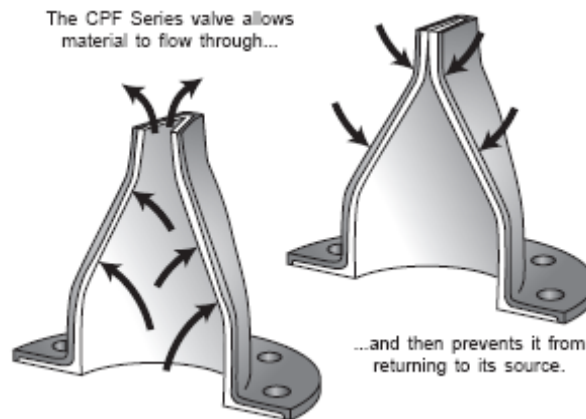

Figure 1

Storage Procedures:

- Duckbill check valves should be stored vertically (**Figure 2a**) with the bill facing upward, not on its side, (**Figures 2b**) in a cool, dry location with maximum ventilation.
- Check valves should not be stacked nor should anything be stored on top of the valves' bills. They should remain on a skid until ready for use.
- Do not drop, bend, or twist the valve as damage may occur.
- The valve should be wrapped in black plastic to avoid contact with sunlight and/or ultra-violet light. This will extend the shelf life.
- Avoid exposure to light, electric motors, dirt, or chemicals. Resilient check valves are subject to deterioration when exposed to ozone and non-compatible chemicals. Ozone, especially, may cause the rubber to harden and become brittle.
- Store the Installation Operation Manual with the valve so it will be readily available for installation.



YES
Figure 2a

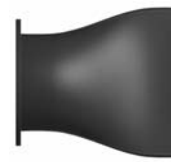

NO
Figure 2b

Components and Terminology (refer to diagram below)

- Cuff:** The round portion of the valve connecting the flange to the valve taper.
- Taper:** The taper transforms the round shape of the valve cuff to the vertical shape of the valve bill. Reinforcement in the taper is customized to suit each application's expected inlet pressures and backpressures.
- Bill:** The outlet end of the valve. The bill contorts to allow flow through the valve yet closes tight during 'no flow' or reverse pressure conditions. The bill can be straight or curved (depends on application).
- Tube:** The inner surface or valve 'sleeve'. This is constructed using an elastomer most suitable for the process fluid.
- Cover:** The outer surface of the valve. This is made from an elastomer most suitable for the expected operating conditions (usually made from EPDM due to its resistance to light and heat).
- Retaining Ring:** Supplied with the valve, the duckbill flange is 'sandwiched' between the mating pipe flange and the retaining ring.
- Line Pressure:** The fluid pressure applied to the valve inlet (used to open the valve).
- Backpressure:** The fluid pressure exerted on the valve outlet. Usually measured in feet or meters of fluid above the pipe invert.

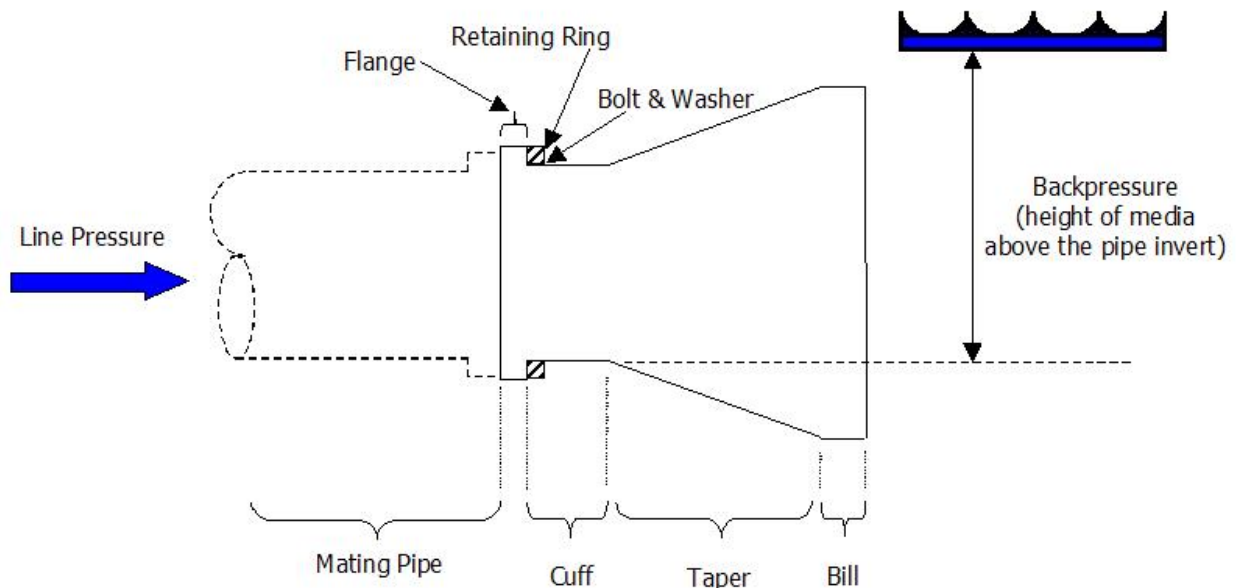

Installation Procedures:

Preferred Orientation

For best performance, bills should be installed as close to the vertical position as possible. In cases where clearance below the pipe outlet is minimal, the duckbill should be rotated only enough as required to avoid contact with the ground. Please contact your EVR representative or EVR's offices directly to discuss this application (1-800-461-6331).

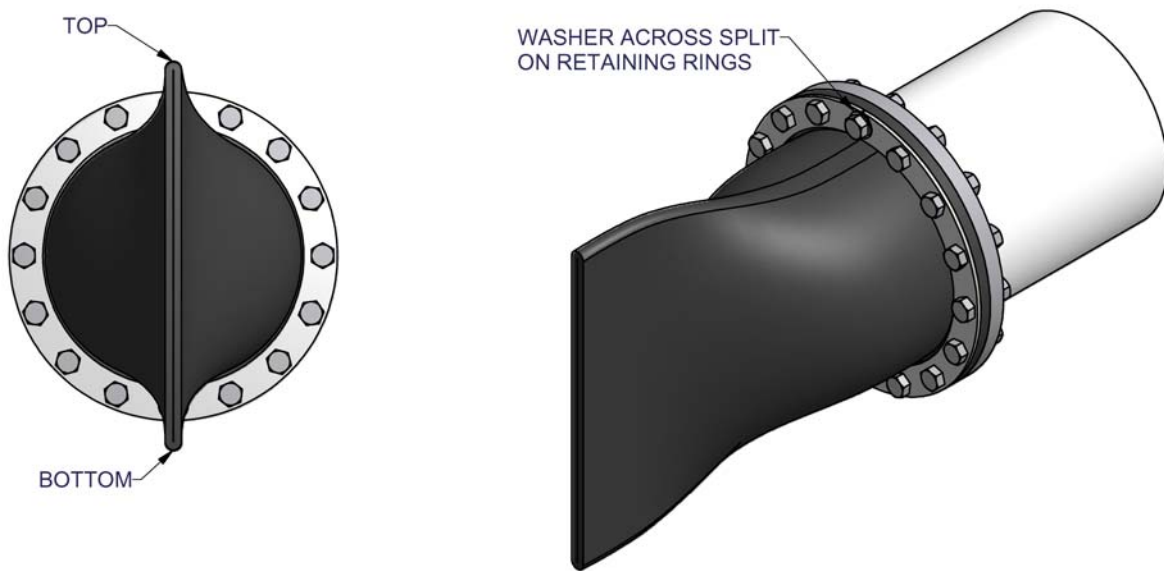

Figure 3

1. Remove all burrs or sharp edges from the pipe flange faces and wipe clean of oil, grease, etc. Apply a thin coat of graphite or glycerine to the pipe flange face. This will ease installation and allow for easy removal at a later date.
2. Lift the duckbill check valve into position and align the bolt holes of the pipe flange, check valve flange and the retaining ring. Ensure the check valve's bill is oriented in a vertical position or as nearly vertical as is possible (rotate if limited ground clearance is available). **Note: For Duckbill Check Valves 14" and larger, we recommend nylon slings be used for lifting valves into position during installation.**
3. After the duckbill check valve and retaining ring are in the correct position, push two (2) bolts through to ensure alignment. After the proper alignment has been obtained, install remaining bolts and nuts, using washers at the split holes -if the Check Valve comes with a retaining ring (See Figure 3).

4. Use two wrenches to prevent torque when installing the Check Valve. Tighten all flange bolts in a criss-cross pattern similar to the one shown in Figure 4 to the maximum torque recommended in Figure 5.
5. Do not weld near the Check Valve.

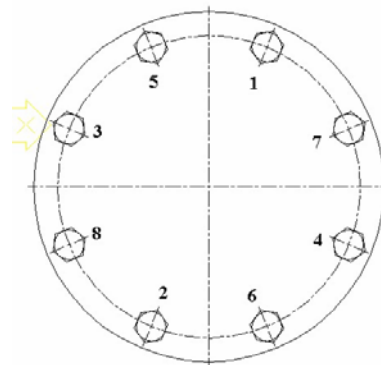

Figure 4

Pipe Size ID (in)	Torque (ft-lbs)	Torque (Nm)
1 - 2	20	27
2.5 – 5	25	34
6 – 12	35	48
14 – 18	50	68
20 and larger	60	82

¹ Torque settings as recommended by the Fluid Sealing Association Std FSA-PSJ-702-06 "Rubber Flanged Non-Metallic Expansion Joint Installation, Maintenance and Storage" Manual

Figure 5

Notes:

- a) To prevent leakage, the flange bolts should be retightened after one week of operation and checked periodically thereafter.
- b) Torque values are approximate. After installation the system should be pressurized and examined to confirm a proper seal. For hydrostatic systems, torque values may need to be increased.

IMPORTANT NOTE: Debris caught under the valve can potentially effect its operation. Therefore, make certain there is 6" of ground clearance between the bill of the valve and the ground during and after installation.

Installation Problems:

If the valve does not fit properly:

- During the installation, if fit appears to be a problem, contact your EVR representative or EVR's office at 1-800- 461-6331.

If the valve will not close fully or check flow in the reverse direction:

- Possible obstruction in the line. Inspect the valve for entrapped foreign objects, which may have lodged between the lips of the valve.
- Insufficient clearance may exist below the valve (forcing it open). Verify there is clearance between the bottom of the bill and the ground and that no debris is trapped between the ground and the valve bottom.
- The backpressure may not be sufficient to seal the bill completely.

If the valve leaks between the flanges:

- Check that all bolts are sufficiently tightened. Increase the torque on all bolts by 5 ft-lbs in a cross pattern. Continue this procedure until the leakage stops.
- Check that no foreign material has become lodged between the mating flanges.

Maintenance:

- Periodically, an inspection should be performed to verify the valve's performance.
- If a build up of debris occurs within the valve, line pressure should flush it out. In some instances, a wooden plank 1" x 4" or 1½" x 12" may be **temporarily** inserted into the bill of the valve and rotated 90°. This will clear the check valve of any debris that may be trapped in the bill.
- A periodic visual inspection of the valve is also a good idea. Inspect the tube and cover for cuts, checking, and fissures. Do not be alarmed if small cuts have formed in the outer cover. If necessary, repairs can be made on site with a repair compound. If significant fissures are noticed where fabric is exposed and torn, the valve must be replaced. Upon inspection of the inside of the bill, if blisters, deformation, or delamination is noted, this is an indication that the media or higher than expected temperatures are attacking the tube. The valve should be replaced as soon as possible. Further research into the actual operating conditions (media & temperature), is required so that a more appropriate check valve may be supplied. Please contact your EVR representative or EVR's office (1-800-461-6331) to discuss any concerns you may have regarding duckbill check valves.

Additional Tips

Do not modify the valve without first consulting EVR's Technical Staff. Doing so would void your warranty.

Do not over-torque flange bolts.

Use metal washers - at least where the bolts go through the retaining ring split holes.

Keep the valve in its proper shipping package and in an upright position until ready for installation.

Tighten the valve flange bolts evenly.

Warranty:

Our warranty as expressed on the back of all "EVR" brochures is as follows:

All EVR products are guaranteed for one full year against defects resulting from faulty workmanship or materials. If any such product is found to be defective, by reason of faulty workmanship or materials, upon written notice and return of the product, the defective product will be replaced by us free of charge, including the shipping charges for the replacement product. Claims for labour costs and other expenses required to replace such defective product, or to repair damage resulting from the use thereof will not be allowed by us. Our liability is limited to the price paid for the defective product. EVR Products shall not be bound by any warranty other than the above set forth unless such warranty shall be in writing. This literature is published in good faith and is believed to be reliable, however, EVR Products does not represent and/or warrant in any manner the above information and suggestions contained in this brochure. Data presented is the result of laboratory tests and field experience.

*** CURVED-BILL CHECK VALVES ARE NOT SOLD IN THE UNITED STATES OF AMERICA.**